

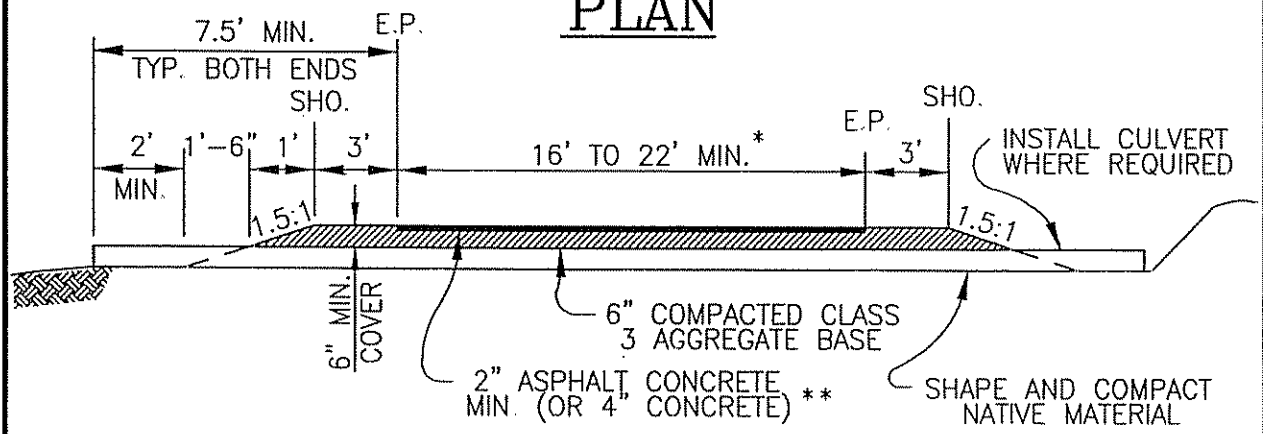

PLAN



TYPICAL SECTION

* WIDER WIDTHS MAY BE REQUIRED, AS DETERMINED BY **D/P/W**
 ** CONCRETE FORMS TO BE INSPECTED BY **D/P/W** PRIOR TO PLACEMENT

SCALE: NTS		DATE: 1996	SHASTA COUNTY DEPARTMENT OF PUBLIC WORKS	
		APPROVED BY:		<i>TYPE 'A'</i> <i>ROAD</i> <i>CONNECTION</i>
		 WILLIAM E. LYMAN		
MARK	DATE	REVISION		

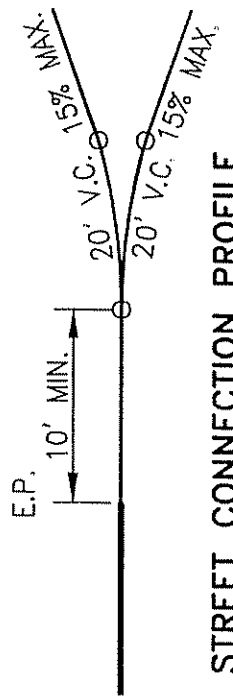

STREET CONNECTION PROFILE

NOTE: MAXIMUM GRADE CHANGE AT VERTICAL CURVE CAN BE 18%.

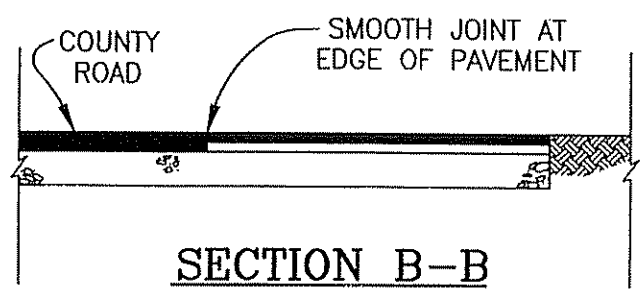

SECTION B-B

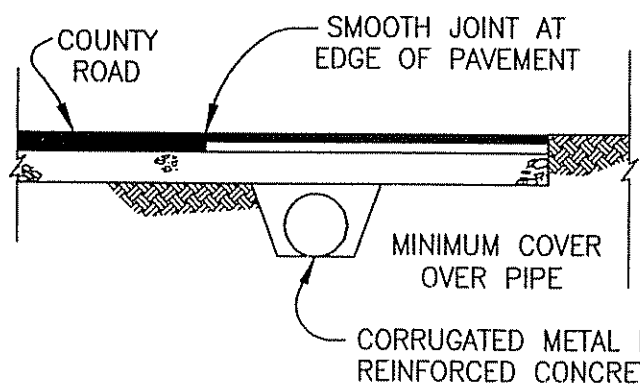

SECTION B-B WITH CULVERT

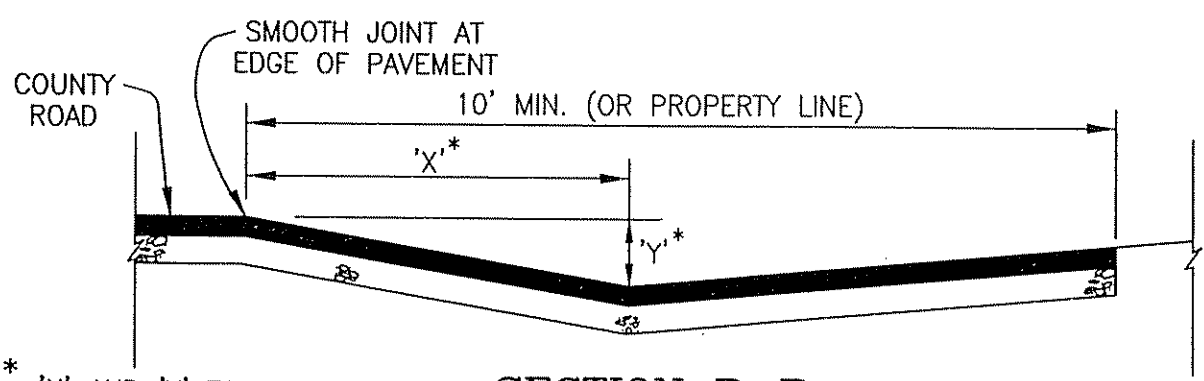

* 'X' AND 'Y' TO BE SPECIFIED BY **D/A/W**

SECTION B-B PAVED DIP

SCALE: NTS		DATE: 1996	SHASTA COUNTY DEPARTMENT OF PUBLIC WORKS	
		APPROVED BY:		TYPE 'A' ROAD CONNECTION
		<i>William E. Lyman</i>		
MARK	DATE	REVISION	WILLIAM E. LYMAN	