



United States
Department of
Agriculture
Forest Service
Pacific Northwest
Research Station

General Technical
Report
PNW-GTR-364
February 1996



Guidelines for Estimating Volume, Biomass, and Smoke Production for Piled Slash

Colin C. Hardy



EXHIBIT 1

Abstract

Hardy, Colin C. 1996. Guidelines for estimating volume, biomass, and smoke production for piled slash. Gen. Tech. Rep. PNW-GTR-364. Portland, OR: U.S. Department of Agriculture, Forest Service, Pacific Northwest Research Station. 17 p.

Guidelines in the form of a six-step approach are provided for estimating volumes, oven-dry mass, consumption, and particulate matter emissions for piled logging debris. Seven stylized pile shapes and their associated geometric volume formulae are used to estimate gross pile volumes. The gross volumes are then reduced to net wood volume by applying an appropriate wood-to-pile volume packing ratio. Next, the oven-dry mass of the pile is determined by using the wood density, or a weighted-average of two wood densities, for any of 14 tree species commonly piled and burned in the Western United States. Finally, the percentage of biomass consumed is multiplied by an appropriate emission factor to determine the mass of PM, PM10, and PM2.5 produced from the burned pile. These estimates can be extended to represent multiple piles, or multiple groups of similar piles, to estimate the particulate emissions from an entire burn project.

Keywords: Fuel, emissions, piled slash, smoke management.

Contents

- 1 **Introduction**
- 2 **The Six-Step Process**
- 3 Step One—Total Gross Volume of the Pile
- 10 Step Two—Net Volume of the Woody Biomass
- 10 Step Three—Density or Weighted-Average Density of the Wood
- 12 Step Four—Consumable (Oven-Dry) Mass of Wood
- 13 Step Five—Proportion of Mass Consumed
- 13 Step Six—Mass of Particulate Matter Produced
- 14 **Recommendations and Guidance**
- 15 **Literature Cited**
- 16 **Appendix 1: A Hypothetical Example**
- 18 **Appendix 2: Full-Sized Copies of the Nomagrams**

Introduction

The guidelines in this document address the critical need to quantify both biomass consumption and the air quality impacts from the burning of piled woody debris. Piling and burning of woody debris from activities such as timber harvesting, road building, and residential or commercial development has been a common practice for as long as these activities have occurred. It is an especially common forestry practice, where logging residue (slash) is piled on the site by bulldozers, and on the terminus (landing) of yarding and skidding trails by bulldozers, cable-yarding equipment, and log loaders. Numerous objectives are met by piling and burning: reduction of on-site woody fuel loading and the resultant reduction in harvest-created fire hazard; scarification of the surface layer and exposure of mineral soil to enhance regeneration of trees; removal of woody and organic material from roadbeds and structure sites to improve the integrity of the construction substrate; and sanitation disposal of stumps and roots infected by disease or pathogens. In some cases, logging slash is piled in anticipation of subsequent use in nonlumber markets such as combustion for energy (hog fuel), pulp chips, and firewood.

On-site burning of piled slash has both negative and positive implications for smoke management. Burning of woody biomass, regardless of its condition and distribution, creates products of incomplete combustion such as carbon monoxide, methane, and particulate matter. A variety of research methods have produced much new knowledge about the quantity and characteristics of smoke emissions from vegetation fires (Ward and Radke 1993) and from piled slash (Ward and others 1989). Piling and burning of slash has positive smoke management implications as well. In contrast with broadcast burning of the same material, piled slash burns more efficiently, with notably less smoke produced per unit mass of fuel consumed (Ward and others 1989). Further, piled slash can be burned under a broad range of weather conditions. This enables the burning of piles to be scheduled for periods of optimal dispersion and also during periods when the conflicts with impacts from other sources are minimized.

Smoke management programs in several Western States now actively encourage the piling and burning of slash, where possible, instead of the more typical practice of broadcast burning. Permitting and fee structures have created incentives for piling and burning. The increased emphasis on the practice demands significant improvements in our ability to quantify preburn fuel loadings, fuel consumption, and emissions production from burning piles.

Several previous efforts have led the way toward the methods and guidelines presented here. Techniques for estimating weights of piles and stumps were developed from a land clearing project in Washington (Mohler 1977). Relations between easy-to-measure dimensions and woody fuel volumes were developed by McNab (1980) for inventorying windrowed forest residues in the Southern United States. Results from these two methods were verified by Johnson (1981) when he compared them to results from destructive sampling. Little developed a method for estimating pile volumes using four stylized shapes and respective volumetric formulae.¹ These shapes, when combined with a ratio estimator for reducing gross pile volume to net wood volume, provide an efficient, simple method for field estimation of woody fuel volumes in piles.

The initial steps in these guidelines use the methodology and generalized shapes presented by Little (see footnote 1). Three additional shapes are included, as are species-specific wood densities, a range of wood-to-pile volume ratios,² and several nomograms intended to reduce the number of manual calculations required to estimate volumes, mass, and smoke emissions.

The Six-Step Process

Six steps are required to estimate particulate emissions from a pile. The product from each step is both relevant in itself and a prerequisite parameter for completion of the next step.

Determine:

1. Total gross volume of the pile.
2. Net volume of the woody biomass.
3. Density or weighted-average density of the wood.
4. Consumable (oven-dry) mass of wood.
5. Proportion of mass consumed.
6. Mass of particulate matter produced (PM, PM10, PM2.5).

¹ Little, S.N. 1980. Estimating the volume of wood in large piles of logging residue. Portland, OR: U.S. Department of Agriculture, Forest Service, Pacific Northwest Forest and Range Experiment Station. 7 p. Administrative Report PNW-1. On file with: Forestry Sciences Laboratory, P.O. Box 3890, Portland, OR 97208-3890.

² Hardy, Colin C., Vihnanek, R. Packing ratios for piled woody debris. Manuscript in preparation. USDA Forest Service, Pacific Northwest Research Station, Seattle, WA 98105.

Step One—Total Gross Volume of the Pile

A. Select a representative pile shape—A pile can be categorized into one of the seven generalized shapes shown in figure 1. The number for each shape is its "shape code." The dimensions required to compute volumes are shown in figure 1 for each shape. Choose the shape most similar to your pile(s) from the following descriptions and figures and record the appropriate dimensions.

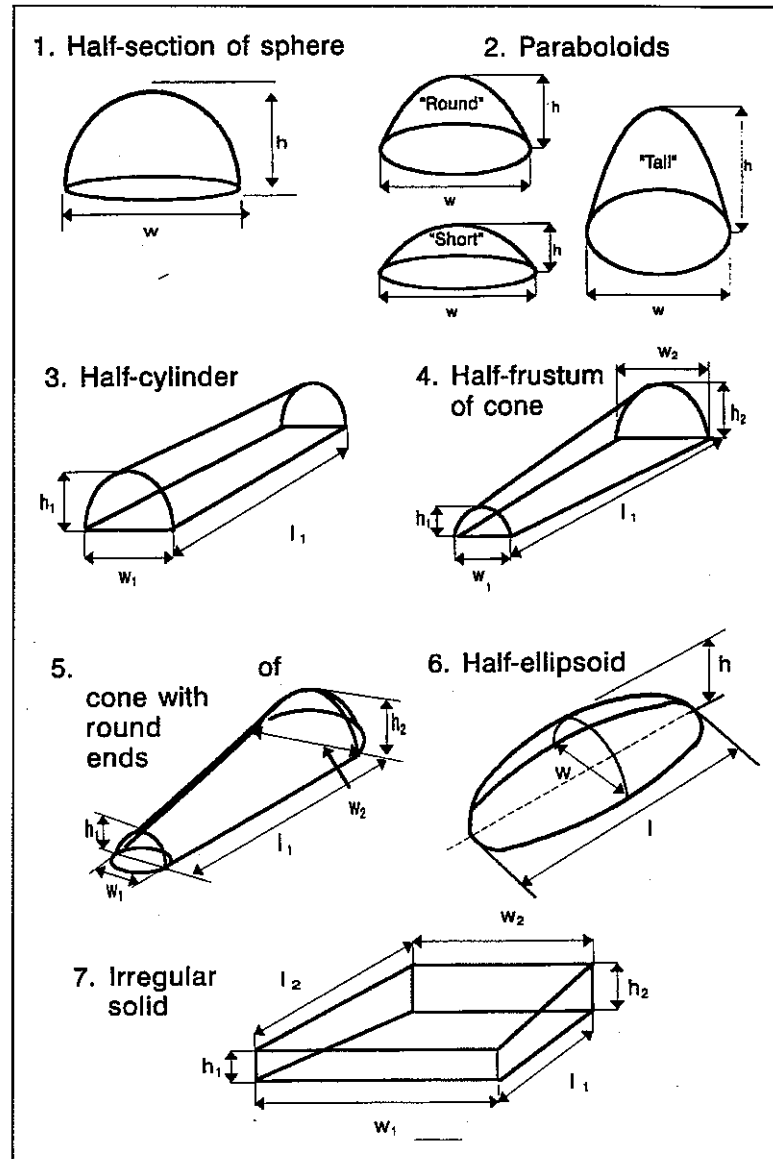

Figure 1—Five generalized pile shapes are used to represent the possible configurations of piled woody debris. Each illustration is numbered by its "shape code" (see text).

Shape code 1: Half-section of a sphere—Truly half of a ball or sphere (fig. 2). The base is round, the width is twice the height, and the sides are well- and evenly-rounded. (Observe and record either height [h] or width [w].)

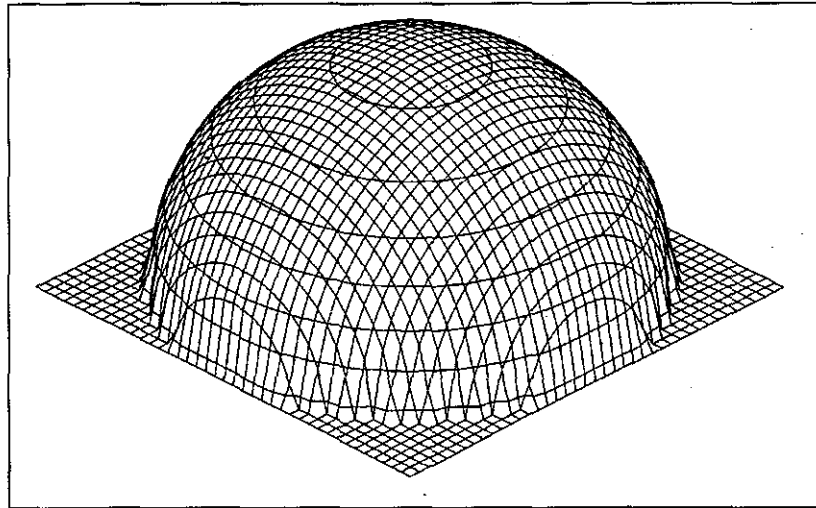

Figure 2—The half-section of a sphere is truly half a ball, with well-rounded sides.

Shape code 2: Half-paraboloid—The base is round, but the sides are parabolic, not round. Three variations of the half-paraboloid shape are shown in figure 3: half-round paraboloid, half-“tall” paraboloid, and half-“short” paraboloid. (Observe and record height [h] and width [w].)

Shape code 3: Half-cylinder—The pile is generally rounded side-to-side, with both ends of the pile approximately the same height and straight (fig. 1). Logs stacked parallel by a loader or crane can form this shape. (Observe and record width [w], height [h], and length [l].)

Shape code 4: Half-frustum of a cone—This shape is similar to a half-cylinder, but the cylinder tapers lengthwise, so the heights of the ends are different (fig. 1). This shape is seen when logs are stacked parallel, with the tapers oriented in the same direction. (Observe and record length [l] and heights or widths of the small and large ends [h_1 or w_1 , and h_2 or w_2].)

Shape code 5: Half-frustum of a cone with rounded ends—Similar to shape code 4, but the ends are rounded (fig. 1). In this case, the rounded ends caused by uneven stacking and mixed piece sizes can add considerable volume to the pile. (Observe and record length of straight section of the side [l] and width of the small and large end [w_1 , w_2].)

A — "Round" paraboloid

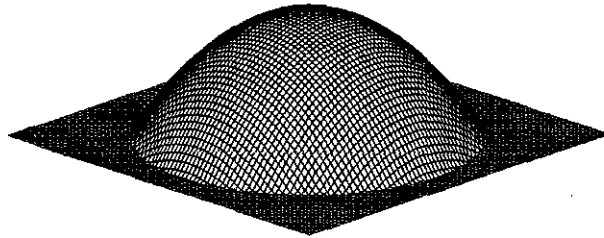

B — "Tall" paraboloid

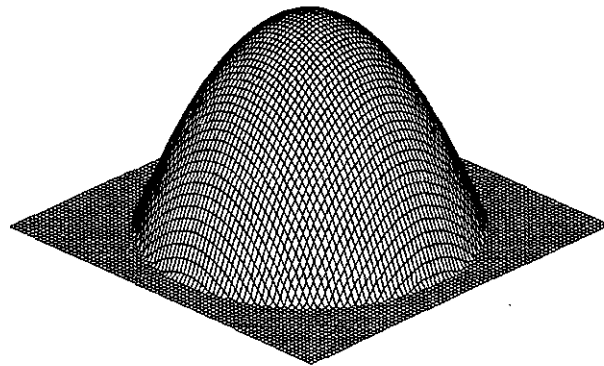

C — "Flat" paraboloid

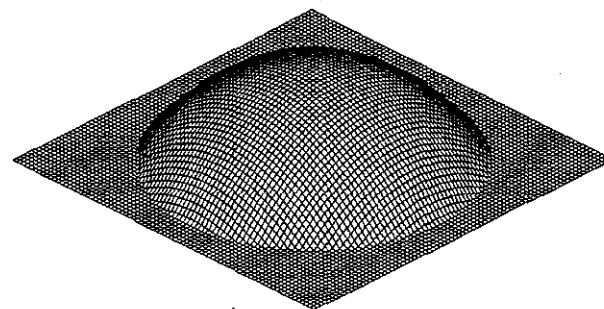

Figure 3—The base of the half-paraboloid is round but the sides are parabolic. Three variations of this shape use the same volumetric formula: (A) "round," (B) "tall," and (C) "flat."

Shape code 6: Half-ellipsoid—This pile is elongated, rounded side-to-side, with well-rounded ends (fig. 4). This shape is typical of windrowed slash. (Observe and record height [h], total length [l], and width at the widest section [w].)

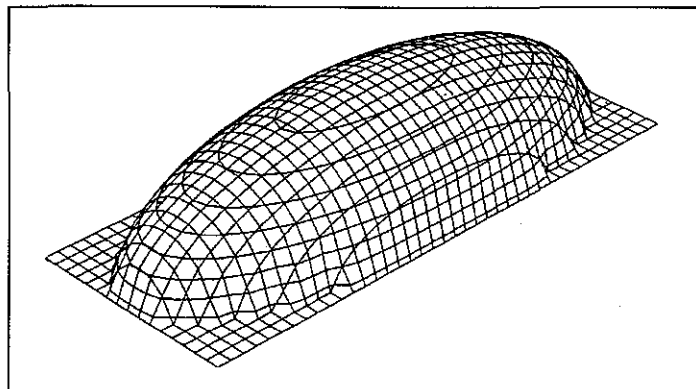

Figure 4—The half-ellipsoid shape represents a long, symmetric, tapering pile with well-rounded ends.

Shape code 7: Irregular solid—This pile is irregularly shaped with straight but uneven sides (fig. 1). The dimensions for opposing sides are not necessarily equal. (Observe and record lengths [l_1 , l_2], widths [w_1 , w_2], and heights [h_1 , h_2].)

B. Calculate the gross volume—The gross volume for a pile represented by any of the seven shape codes can be calculated from the following volumetric formulae,

where: V = gross pile volume (cubic feet),

l, l_1, l_2 = length(s) in feet,

h, h_1, h_2 = height(s) in feet, and

w, w_1, w_2 = width(s) in feet.

Look-up tables or nomagrams are provided for some of the shapes and are referenced below with the respective formula.

Shape code 1—

$$V = \frac{2\pi h^3}{3} \text{ or } V = \frac{\pi h w^2}{6}$$

Columns 1-3 of table 1 contain look-up data for this volume. Use either pile height (column 2) or pile height and width (column 1) to determine gross volume (column 3).

Table 1—Gross pile volumes for half-section of a sphere (spheroid) and half-paraboloid pile shapes (shape codes 1 and 2, respectively)^a

Pile width	Spheroids only		Volume by paraboloid height (in feet)								
	Height	Volume	4	6	8	10	12	14	16	18	20
-- Feet --			----- Cubic feet -----								
4	2.0	17	25	38	50	63	75	88	101	113	126
5	2.5	33	39	59	79	98	118	137	157	177	196
6	3.0	57	57	85	113	141	170	198	226	254	283
7	3.5	90	77	115	154	192	231	269	308	346	385
8	4.0	134	101	151	201	251	302	352	402	452	503
9	4.5	191	127	191	254	318	382	445	509	573	636
10	5.0	262	157	236	314	393	471	550	628	707	785
11	5.5	348	190	285	380	475	570	665	760	855	950
12	6.0	452	226	339	452	565	679	792	905	1018	1131
13	6.5	575	265	398	531	664	796	929	1062	1195	1327
14	7.0	718	308	462	616	770	924	1078	1232	1385	1539
15	7.5	884	353	530	707	884	1060	1237	1414	1590	1767
16	8.0	1072	402	603	804	1005	1206	1407	1608	1810	2011
17	8.5	1286	454	681	908	1135	1362	1589	1816	2043	2270
18	9.0	1527	509	763	1018	1272	1527	1781	2036	2290	2545
19	9.5	1796	567	851	1134	1418	1701	1985	2268	2552	2835
20	10.0	2094	628	942	1257	1571	1885	2199	2513	2827	3142
21	10.5	2425	693	1039	1385	1732	2078	2425	2771	3117	3464
22	11.0	2788	760	1140	1521	1901	2281	2661	3041	3421	3801
23	11.5	3185	831	1246	1662	2077	2493	2908	3324	3739	4155
24	12.0	3619	905	1357	1810	2262	2714	3167	3619	4072	4524

^a The volume for a spheroid (column 3) is determined from either the width (column 1) or height (column 2). For a half-paraboloid, find the intersection of width (column 1) and height (columns 4-12).

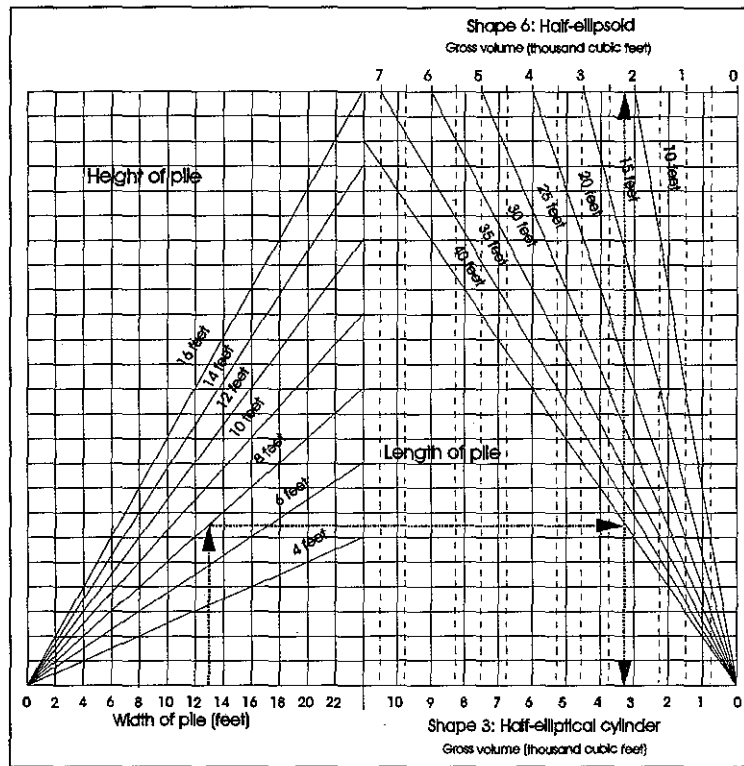

Figure 5—The nomogram assists in determining gross pile volumes (X-axes at upper and lower right) for shape codes 6 and 3, respectively, by width (X-axis at lower left), height (diagonal lines at left), and length (diagonal lines at right).

Shape code 2—

$$V = \frac{\pi h w^2}{8}$$

The volume for any of the three variations of half-paraboloid is derived from the same equation. Columns 1 and 4-12 of table 1 contain look-up data for this volume, where the intersection of width (column 1) and height (columns 4-12) contains the gross pile volume.

Shape code 3—

$$V = \frac{\pi w l h}{4}$$

Figure 5 is a nomogram for estimating gross volumes for shape codes 3 and 6 by using width, height, and length.³

Begin at the X-axis (horizontal axis) labeled "width of pile"; go up from the correct width to the diagonal line for the correct height; go horizontally to the diagonal line at the right for the correct length; go down to the right-hand X-axis (labeled "gross volume") for shape code 3, half-elliptical cylinder, to determine the gross pile volume.

³ Full-page versions of all nomograms are given in appendix 2.

Shape code 4—

$$V = \frac{\pi l_1 [h_1^2 + h_2^2 + (h_1 h_2)]}{6} \text{ if using heights,}$$

or

$$V = \frac{\pi l_1 [w_1^2 + w_2^2 + (w_1 w_2)]}{24} \text{ if using widths.}$$

Shape code 5—

$$V = \frac{\pi \{ l_1 [w_1^2 + w_2^2 + (w_1 w_2)] + w_1^3 + w_2^3 \}}{24}$$

Shape code 6—

$$V = \frac{\pi w l h}{6}$$

Figure 5 is a nomogram for estimating gross volumes for shape codes 3 and 6 by using width, height, and length.

Begin at the X-axis (horizontal axis) labeled "width of pile"; go up from the correct width to the diagonal line for the correct height; go horizontally to the diagonal line at the right for the correct length; go up to the top right-hand X-axis (labeled "gross volume") for shape code 6, half-ellipsoid, to determine the gross pile volume.

Shape code 7—

$$V = \frac{(l_1 + l_2)(w_1 + w_2)(h_1 + h_2)}{8}$$

Some piles contain a significant amount of soil, whether entrained among the wood pieces or mounded beneath the pile. The net wood volume must be reduced by an estimate of the percent of the volume occupied by soil.

Step Two—Net Volume of the Woody Biomass

Much of the gross volume of a pile is occupied by air. The ratio of wood volume to total pile volume is called the "packing ratio." The gross pile volume must be multiplied by an appropriate packing ratio to determine the net volume of woody material in a pile. Research on the packing ratio of piled slash has determined that the net wood volume can range from as low as 6 percent to as high as 26 percent (see footnote 2). These values represent extremes from 17 piles studied. The variation in packing ratio is due to numerous factors, including piling specifications, operator and machine performance, species content, and size class distribution. Only expert judgment can be used to ultimately determine a packing ratio for a particular pile or group of similar piles. For the purpose of these guidelines, data from research can be used to suggest the following packing ratios:

- Piles with species content dominated by ponderosa pine, with mean diameters of the large woody fuel of less than 10 inches were found to have a mean packing ratio of 10 percent (0.10).⁴
- Piles dominated by short-needled conifers had packing ratios ranging from 15 percent (0.15) to 20 percent (0.20).
- Highly compacted, clean piles with larger logs (diameters greater than 10 inches), especially those built with a crane or loader, can have packing ratios as high as 25 percent (0.25).

Multiply the gross pile volume determined in step one by an appropriate packing ratio to calculate net wood volume. The nomagram shown on the left side of figure 6 can be used to make this calculation. Begin at the X-axis labeled "gross pile volume"; go up to a diagonal line representing an appropriate packing ratio for the pile(s); go left to the Y-axis to determine the respective net wood volume. This step can be combined with step four if the nomagram is used.

Step Three—Density or Weighted-Average Density of the Wood

The oven-dry density of wood is used to calculate mass of wood for fuel loading, fuel consumption, and smoke production. Table 2 contains oven-dry densities for 14 tree species commonly piled and burned in the Western United States. Use these values if the wood in a pile is predominately one species. If two species are identified, refer to the nomagram in figure 7 to derive a weighted-average density for the pile.

First, find a line in figure 7 connecting the two species. Move from the end of the line representing the dominant species towards the other species until the line intersects the correct percentage content (vertical lines labeled on the X-axis) for the dominant species; then move horizontally either left or right to the Y-axis to determine a weighted-average density for the two species.

⁴ Scientific names for tree species are included in table 2.

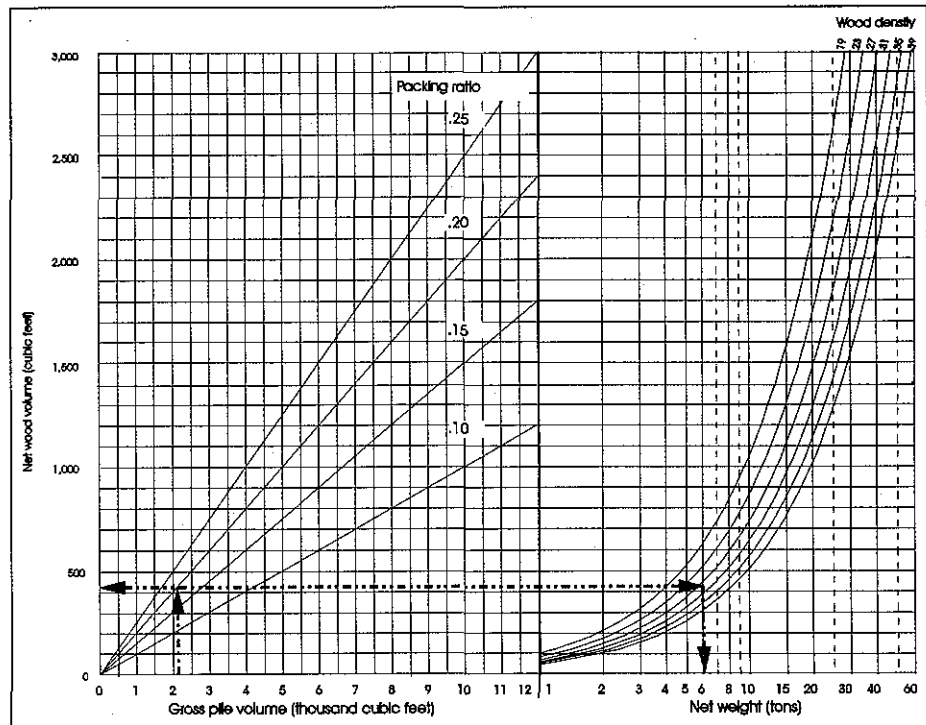

Figure 6—The nomogram assists in determining net mass of the wood (X-axis at right) by using gross pile volume (X-axis at left), packing ratio (diagonal lines at left), net wood volume (Y-axis), and wood density (curves at right).

Table 2—Green specific gravity and oven-dry density for 14 tree species commonly piled and burned in the Western United States

Species	Specific gravity (green)	Density (oven dry)
	Dimensionless	Lb/ft ³
✓ Rotten wood (not species-specific)	0.30	18.7
✓ Western redcedar (<i>Thuja plicata</i> Donn ex D. Don)	.31	19.4
Black cottonwood (<i>Populus trichocarpa</i> Torr. & Gray)	.31	19.4
Quaking aspen (<i>P. tremuloides</i> Michx.)	.35	21.9
✓ True fir (noble) (<i>Abies procera</i> Rehd.)	.37	23.1
✓ Red alder (<i>Alnus rubra</i> Bong.)	.37	23.1
Sitka spruce (<i>Picea sitchensis</i> (Bong.) Carr.)	.37	23.1
✓ Ponderosa pine (<i>Pinus ponderosa</i> Dougl. ex Laws.)	.38	23.7
✓ Lodgepole pine (<i>P. contorta</i> Dougl. ex Loud.)	.38	23.7
✓ Western hemlock (<i>Tsuga heterophylla</i> (Raf.) Sarg.)	.42	26.2
✓ Bigleaf maple (<i>Acer macrophyllum</i> Pursh)	.44	27.5
✓ Wine maple (<i>Acer circinatum</i> Pursh)	.44	27.5
✓ Douglas-fir (<i>Pseudotsuga menziesii</i> (Mirb.) Franco)	.45	28.1
✓ Western larch (<i>Larix occidentalis</i> Nutt.)	.48	30.0
Tanoak (<i>Lithocarpus densiflorus</i> (Hook. & Arn.) Rehd.)	.58	36.2

Sources: Panshin and others 1964, USDA Forest Service 1974.

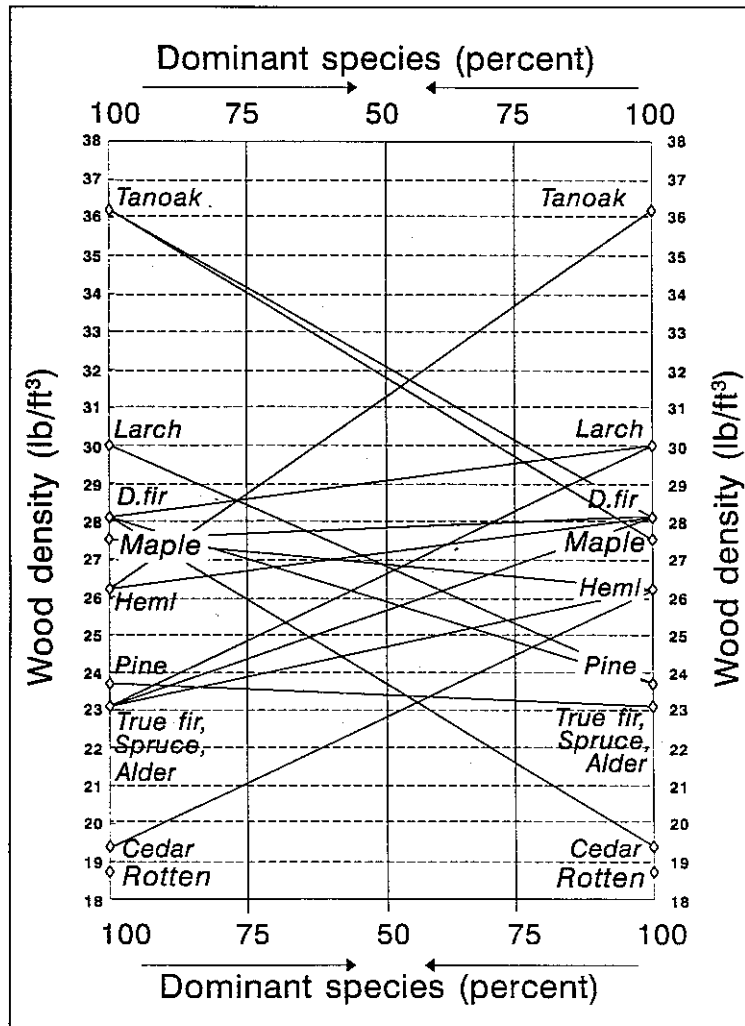

Figure 7—The nomogram can be used to calculate a weighted-average wood density (Y-axes) for two species by finding a point along a diagonal line representing two species that intersects with a vertical line indicating the correct proportion of the two species.

Step Four—Consumable (Oven-Dry) Mass of Wood

Multiply the wood density or weighted-average wood density for the pile by the net wood volume to calculate the oven-dry (consumable) mass of the pile. Divide the result by 2,000 to convert to tons. The nomogram shown on the right side of figure 6 can be used for this step.

Begin with the correct net wood volume shown on the Y-axis at the left side of figure 6; move right, horizontally, to the appropriate wood density curve on the right side of the nomogram; proceed downward (vertically) to determine the net weight of wood in the pile. Note that the X-axis at the right (net weight) is logarithmic, so interpolations must be made only between adjacent numbers on the X-axis.

Step Five—Proportion of Mass Consumed

The percentage of wood mass consumed when piles are burned typically ranges between 75 and 95 percent. Smoke management-reporting programs in several Western States recommend either 85 percent (0.85) or 90 percent (0.90). Experience and expert knowledge must be used to determine the most appropriate value for percentage of consumption. Multiply the percentage by the consumable mass of wood from step four to calculate the total mass of material consumed.

Step Six—Mass of Particulate Matter Produced

The mass of an emission produced by a fire is calculated by multiplying the mass of fuel consumed by an appropriate emission factor for the emission of interest. These guidelines provide emission factors for three size classes of particulate matter: PM (total particulate matter), PM10 (particulate matter smaller than 10 micrometers mean-mass diameter), and PM2.5 (particles smaller than 2.5 micrometers mean-mass diameter). The emission factors for these particle sizes differ with the combustion efficiency of the fire. Cleaner piles burn more efficiently than dirty piles. Consequently, cleaner piles produce less of the products of incomplete combustion, of which particulate matter is a major emission species. Figure 8 provides emission factor curves for PM, PM10, and PM2.5; the relations between the emission factors and combustion efficiency illustrate the impacts of different amounts of soil mixed into a pile. Expert judgment as well as agency policy must be considered when using the curves in figure 8.

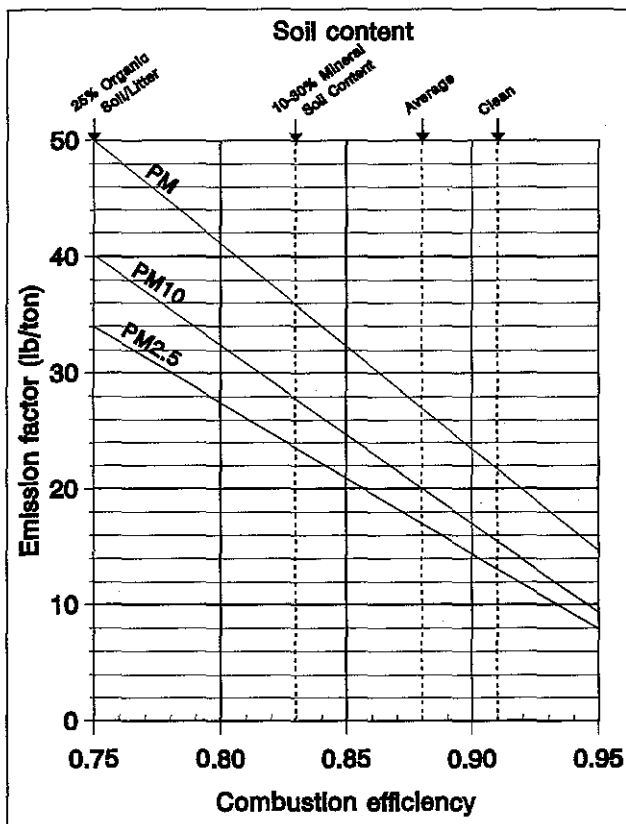

Figure 8—An appropriate emission factor for PM, PM2.5, and PM10 can be determined from knowledge of the relative amount of soil in the pile.

Recommendations and Guidance

Start in figure 8 from an appropriate combustion efficiency determined from the relative cleanliness of the pile(s); combustion efficiency and soil content are found on the lower and upper X-axes, respectively. Follow the vertical line up from combustion efficiency, or down from soil content, to the intersection of the line for PM, PM10, or PM2.5; from that intersection move horizontally left to determine the emission factor.

Multiply the emission factor by the oven-dry mass of material consumed (from step five) to calculate the total mass of the particulate matter emission produced by the pile(s).

The largest errors expected from using these guidelines will occur during the process of determining the gross pile volume(s). The seven stylized pile shapes do not provide an exhaustive choice of geometric shapes for piled slash. These seven are presented because they reflect general shapes observed by the author and other experts, and also because their volumes can be calculated relatively easily from either the formulae or the nomagrams. When the dimensions for a pile are observed, care must be taken to account for irregularities in the pile's surfaces. Try to mentally "smooth" the lobes, ridges, and valleys into an average, smooth surface. Long logs and poles extending from the pile's nominal surface can be accounted for by increasing the dimension(s) of the pile appropriately. If a significant amount of soil is either entrained within the pile or mounded beneath it, the volume of the soil must be estimated and subtracted from the gross pile volume.

The packing ratios presented in these guidelines represent empirical field data from destructive sampling of 17 piles. Even though guidelines are provided to determine an appropriate packing ratio for specific piles, an agency or administrative unit may choose to specify packing ratios for applications under their jurisdiction.

A continuous range of emission factors for PM, PM10, and PM2.5 are presented in these guidelines. The values given for "average" piles are weighted means from eight in situ field tests of emissions from burning of piles of woody debris. Results from many other related tests were used to develop the regression lines (fig. 8), which predict emission factors by using combustion efficiency. The values for PM10 were not derived from actual field observations—only PM2.5 and PM were measured in the field tests from which these data were prepared. PM10 emission factors were estimated by using limited knowledge of the size distribution of particles.

These guidelines provide procedures for estimating volume, biomass, and particulate matter emissions from a single pile. Most applications of these procedures typically will be made for multiple-pile projects. Some or all steps in these guidelines can be extended to represent a group of similar piles. For example, average dimensions can be used for all piles of a similar shape. If possible, it is helpful to map the location, shape, and dimension of each pile on a unit or project. At a minimum, piles of similar shape or size should be tallied; the formulae and nomagrams can then be applied at another time. Each agency or administrative unit may prescribe a specific method for obtaining and aggregating the data for a project.

Literature Cited

- Johnson, V.J. 1981.** How shape affects the burning of piled debris. *Fire Management Notes*. 45(3). 4 p.
- McNab, H.W. 1980.** A technique for inventorying volume and weight of windrowed forest residues. Res. Pap. SE-215. Asheville, NC. U.S. Department of Agriculture, Forest Service, Southeastern Forest Experiment Station. 8 p.
- Mohler, J.P. 1977.** Estimating weight in piled land clearing debris. *Residue Reducer*. [Olympia, WA]: State of Washington, Department of Natural Resources; 2(2). 5 p.
- Panshin, A.J.; DeZeeuw, C.; Brown, H.P. 1964.** Textbook of wood technology—volume 1. New York: McGraw-Hill Book Company. 643 p.
- U.S. Department of Agriculture, Forest Service. 1974.** Wood handbook: wood as an engineering material. Revised. Agric. Handb. 72. Washington, DC.
- Ward, D.E.; Hardy, C.C.; Sandberg, D.V.; Reinhardt, T.E. 1989.** Mitigation of prescribed fire atmospheric pollution through increased utilization of hardwoods, piled residues, and long-needled conifers: Part III—emissions characterization. Seattle, WA: U.S. Department of Energy; final report IAG DA-AI179-85BP18509. On file with: Pacific Northwest Research Station, Fire and Environmental Research Applications Group, Seattle, WA.
- Ward, D.E.; Radke, L.F. 1993.** Emissions measurements from vegetation fires: a comparative evaluation of methods and results. In: Crutzen, P.J.; Goldammer, J.G., eds. *Fire in the environment: the ecological, atmospheric, and climatic importance of vegetation fires*. New York: John Wiley: 53-76. Chapter 4.

Appendix 1: A Hypothetical Example

- **Shape**—The pile was built with a bulldozer and can be considered a windrow. It is elongated, with an elliptically shaped base, and is rounded side-to-side with well-rounded ends.
- **Dimensions**—Length is 40 feet; width is 13 feet; height is 8 feet.
- **Wood species**—Wood content (by volume) is 75 percent Douglas-fir and 25 percent western hemlock.
- **Packing ratio**—Pile is relatively compact; about 20 percent wood-to-volume ratio (0.20).
- **Fuel consumption**—90 percent of the wood mass will be consumed.
- **Emission factors**—The pile is “average” in soil content and therefore will burn with a combustion efficiency of 0.88.

Step one—Total gross volume of the pile—

A. Select a representative pile shape: Pile shape is half-ellipsoid—shape code 6.

B. Calculate the gross volume:

$$\text{Formula method: Volume} = \frac{\pi * 13 * 40 * 8}{6} = 2178 \text{ cubic feet .}$$

Nomogram: Refer to figure 5 and follow the arrowed line to the X-axis at the upper right, where the gross volume equals about 2.2 thousand cubic feet.

Step two—Net volume of the woody biomass—

Formula method: Net volume = Gross volume x packing ratio; therefore,

$$2178 * 0.20 = 435.6 \text{ cubic feet.}$$

Nomogram: Refer to figure 6 and follow the arrowed line to the Y-axis at the left, where the net volume equals about 435 cubic feet.

Step three—Density or weighted-average density of the wood

Formula method: The pile is 75 percent Douglas-fir and 25 percent western hemlock. Refer to table 2 for the densities of Douglas-fir (28.1 lb/ft³) and western hemlock (26.2 lb/ft³). Calculate the weighted average:

$$(0.75 * 28.1) + (0.25 * 26.2) = 27.63 \text{ pounds per cubic foot.}$$

Nomogram: Refer to figure 7, where the diagonal line connecting Douglas-fir and western hemlock intersects the vertical line representing 75 percent Douglas-fir at about 27.7 lb/ft³ (on the Y-axis).

Step four—Consumable (oven-dry) mass of wood—

Formula method: Net wood mass = net wood volume x wood density

$$435.6 \times 27.63 = 12,036 \text{ pounds or } \approx 6 \text{ tons.}$$

Nomagram: Refer to figure 6 and follow the arrowed line to the curves on the right, then down to the X-axis, where the net mass of wood is approximately 6.0 tons.

Step five—Proportion of mass consumed—

Formula method: Mass consumed = net mass x percent consumed

$$6.0 \times 0.90 = 5.4 \text{ tons.}$$

Step six—Mass of particulate matter produced—

Formula: Total emission = mass consumed x emission factor.

Emission factors: Referring to figure 8, for an "average" pile:

$$\text{PM} = 27 \text{ lb/ton}$$

$$\text{PM}_{10} = 20 \text{ lb/ton}$$

$$\text{PM}_{2.5} = 17 \text{ lb/ton}$$

$$\text{Calculate: PM: } 5.4 \text{ tons} \times 27 \text{ lb/ton} = 145.8 \text{ pounds}$$

$$\text{PM}_{10}: 5.4 \text{ tons} \times 20 \text{ lb/ton} = 108.0 \text{ pounds}$$

$$\text{PM}_{2.5}: 5.4 \text{ tons} \times 17 \text{ lb/ton} = 91.8 \text{ pounds}$$

**Appendix 2:
Full-Sized Copies
of the Nomagrams**

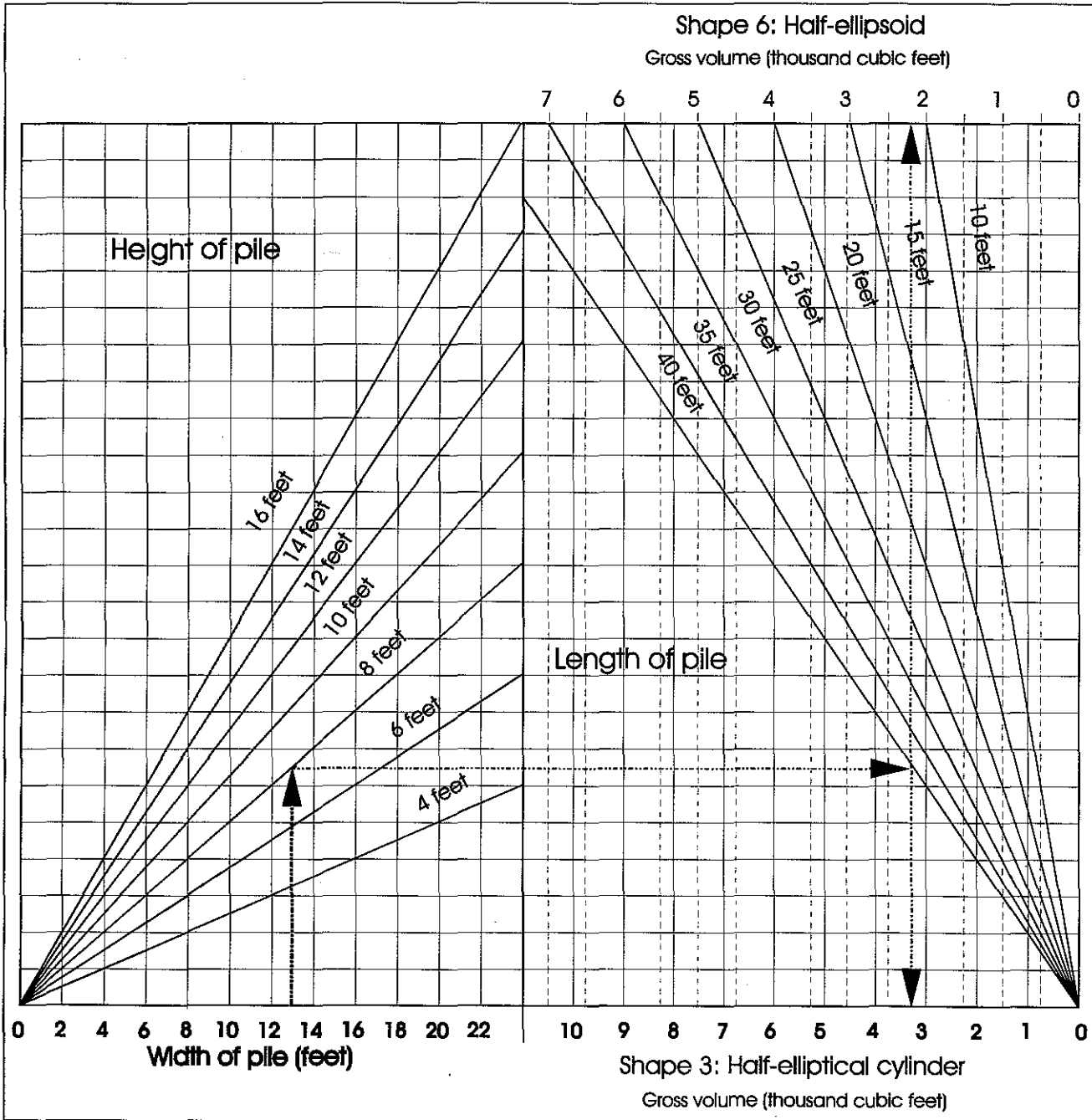

Figure 5—The nomagram assists in determining gross pile volumes (X-axes at upper and lower right) for shape codes 6 and 3, respectively, by width (X-axis at lower left), height (diagonal lines at left), and length (diagonal lines at right).

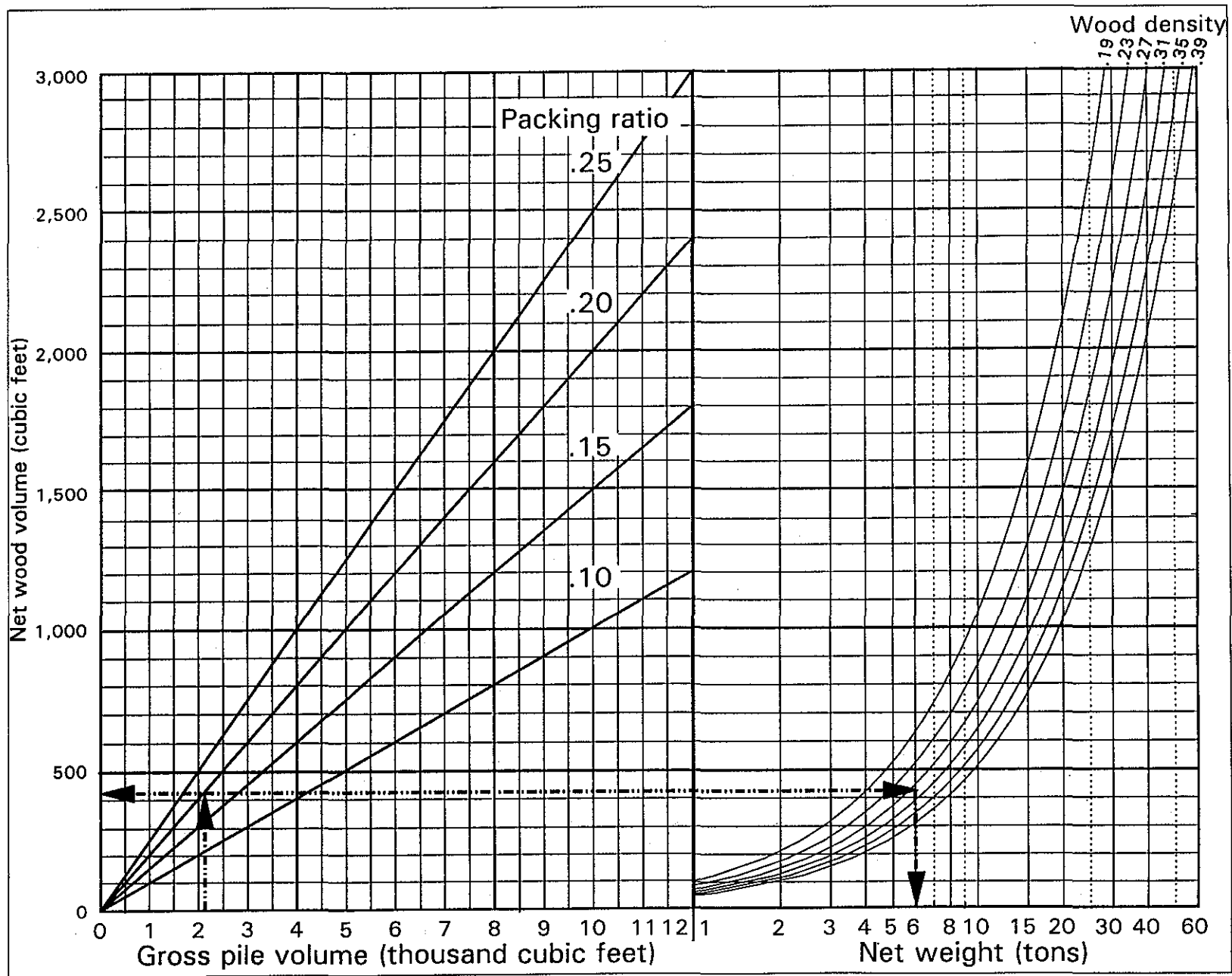

Figure 6—The nomogram assists in determining net mass of the wood (X-axis at right) by using gross pile volume (X-axis at left), packing ratio (diagonal lines at left), net wood volume (Y-axis), and wood density (curves at right).

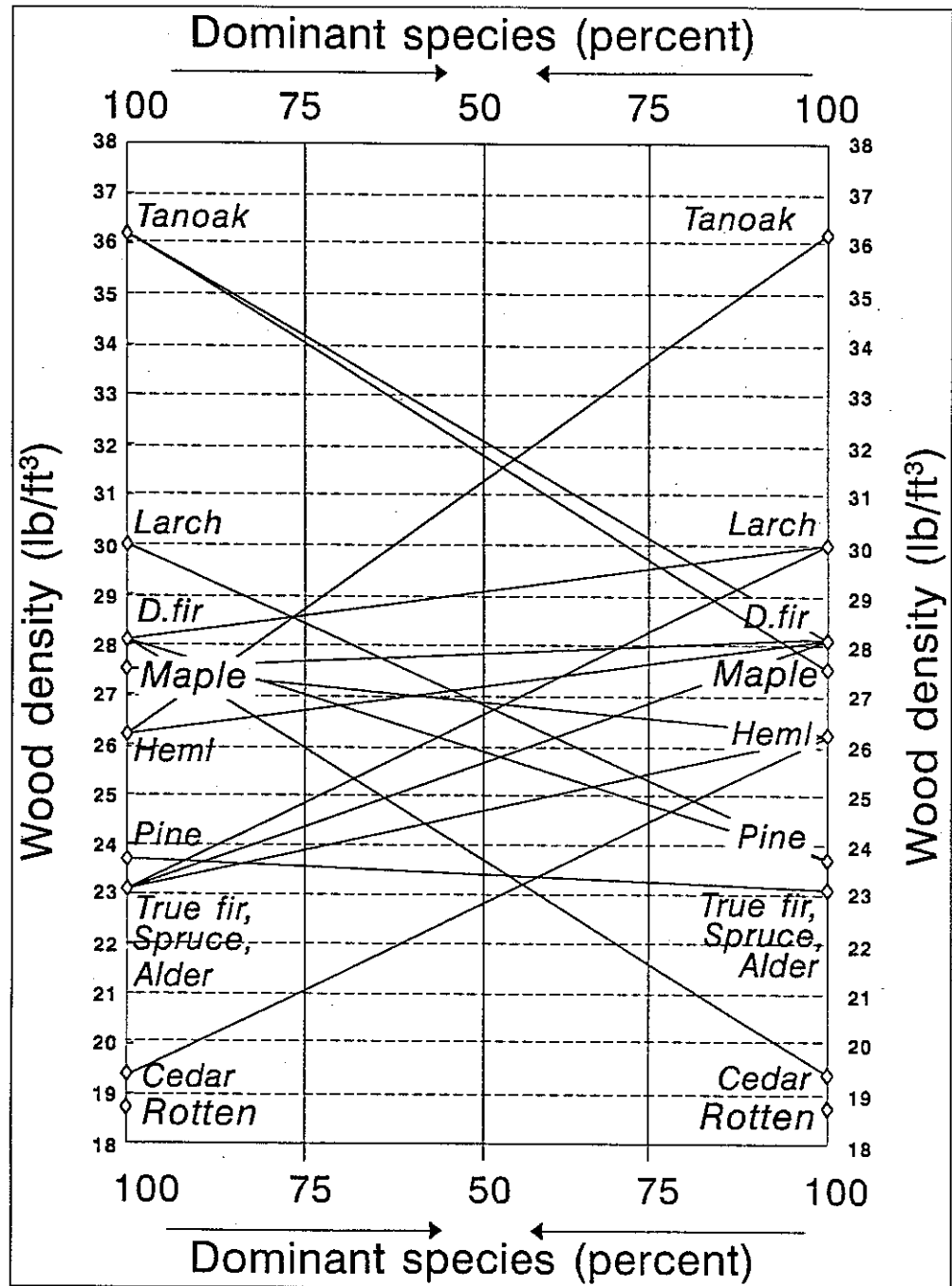

Figure 7—The nomogram can be used to calculate a weighted-average wood density (Y-axes) for two species by finding a point along a diagonal line representing two species that intersects with a vertical line indicating the correct proportion of the two species.

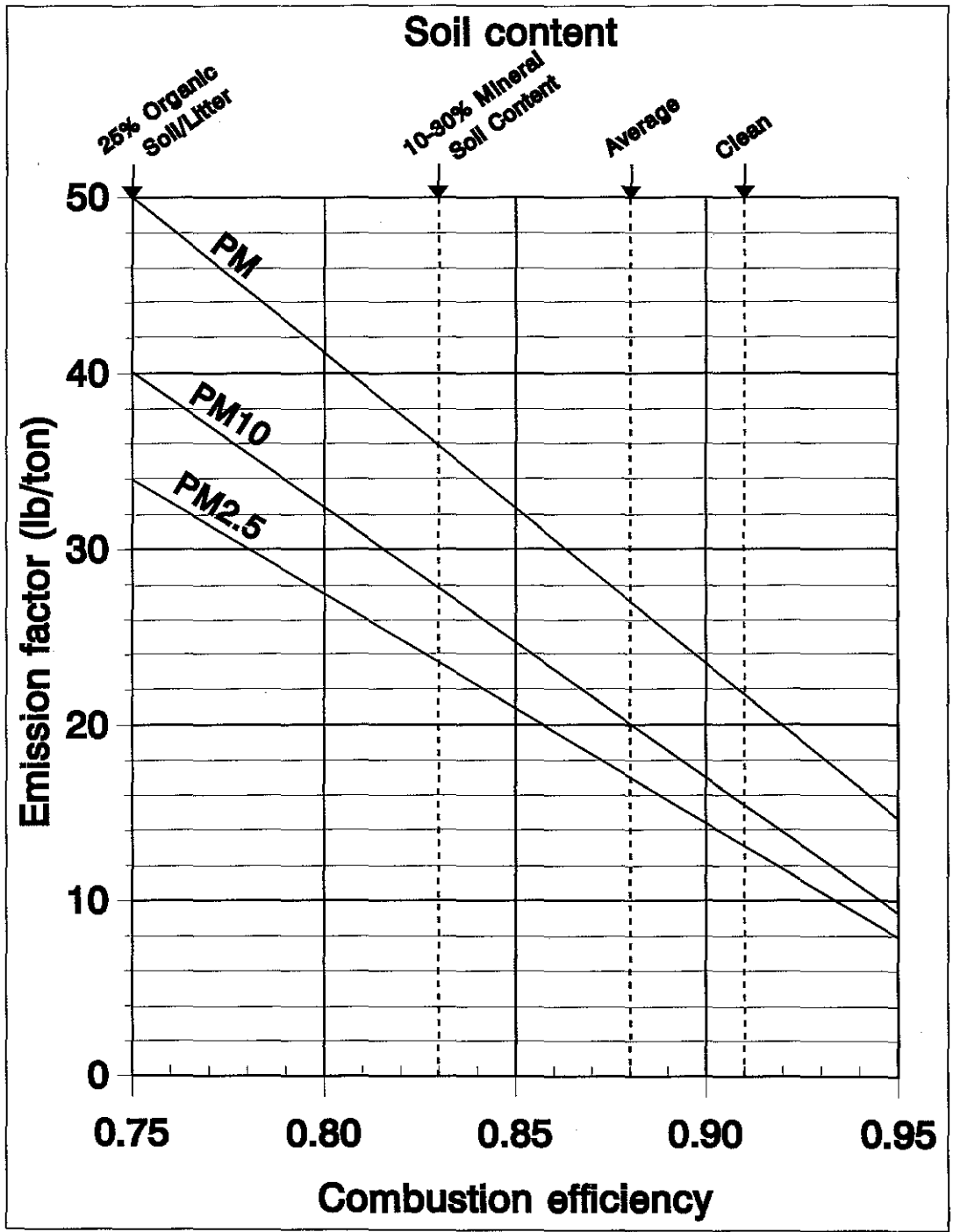

Figure 8—An appropriate emission factor for PM, PM2.5, and PM10 can be determined from knowledge of the relative amount of soil in the pile.

Hardy, Colin C. 1996. Guidelines for estimating volume, biomass, and smoke production for piled slash. Gen. Tech. Rep. PNW-GTR-364. Portland, OR: U.S. Department of Agriculture, Forest Service, Pacific Northwest Research Station. 17 p.

Guidelines in the form of a six-step approach are provided for estimating volumes, oven-dry mass, consumption, and particulate matter emissions for piled logging debris. Seven stylized pile shapes and their associated geometric volume formulae are used to estimate gross pile volumes. The gross volumes are then reduced to net wood volume by applying an appropriate wood-to-pile volume packing ratio. Next, the oven-dry mass of the pile is determined by using the wood density, or a weighted-average of two wood densities, for any of 14 tree species commonly piled and burned in the Western United States. Finally, the percentage of biomass consumed is multiplied by an appropriate emission factor to determine the mass of PM, PM10, and PM2.5 produced from the burned pile. These estimates can be extended to represent multiple piles, or multiple groups of similar piles, to estimate the particulate emissions from an entire burn project.

Keywords: Fuel, emissions, piled slash, smoke management.

The **Forest Service** of the U.S. Department of Agriculture is dedicated to the principle of multiple use management of the Nation's forest resources for sustained yields of wood, water, forage, wildlife, and recreation. Through forestry research, cooperation with the States and private forest owners, and management of the National Forests and National Grasslands, it strives—as directed by Congress—to provide increasingly greater service to a growing Nation.

The United States Department of Agriculture (USDA) prohibits discrimination in its programs on the basis of race, color, national origin, sex, religion, age, disability, political beliefs, and marital or familial status. (Not all prohibited bases apply to all programs.) Persons with disabilities who require alternative means of communication of program information (Braille, large print, audiotape, etc.) should contact the USDA Office of Communications at (202) 720-2791.

To file a complaint, write the Secretary of Agriculture, U.S. Department of Agriculture, Washington, DC 20250, or call (202) 720-7327 (voice), or (202) 720-1127 (TDD). USDA is an equal employment opportunity employer.

Pacific Northwest Research Station
333 S.W. First Avenue
P.O. Box 3890
Portland, Oregon 97208-3890